



Universal multi-channel signal conditioner

EMS750

User manual

Document version: 260426

INTRODUCTION

This manual describes in detail the use of the digital signal conditioner EMS750. It has three parts:

- **A HARDWARE** is a description of the signal conditioner inputs and sensor connections.
- **B SOFTWARE** is a description of the software with which the signal conditioner can be set up and data can be read from it.
- **C EXAMPLES** is a description of the signal conditioner settings using specific examples.

Additional information is available on the manufacturer's website; in case of specific technical questions, it is also possible to write an email or call the manufacturer.

The warranty period is 2 years from the date of purchase of the device. If you require warranty or post-warranty service, please contact the supplier or the manufacturer directly.

Manufacturer contact:

EMSYST, spol. s r. o.
Súvoz 111
911 01 Trenčín
Slovak Republic
Tel. +421 32 7432400
mail@emsyst.sk
www.emsyst.sk

OBSAH

A	HARDWARE	4
1	Safety instructions	4
2	Signal conditioner installation	4
3	Configuring the EMS750 signal conditioner	4
4	Opening the signal conditioner	4
5	User Hardware Configuration	6
5.1	Configuration of inputs CH1, CH2, CH3 CH4 for connecting force sensors	8
5.2	Configuration of input CH1 for voltage measurement 0 ... 10 V	9
5.3	Configuring the CH1 input for 4 ... 20 mA current measurement.....	9
5.4	CH4 channel configuration	10
6	Advanced Configuration	10
7	Technical data	11
B	SOFTWARE	12
1	Control700 Program	12
1.1	Control700 Installation	12
1.2	Deactivating and activating the add-in	12
1.3	Uninstalling an Add-in.....	13
2	Control700, description of functions.....	13
2.1	Connecting to communication ports.....	13
2.2	Connecting the sensor.....	14
2.3	Setting measurement parameters.....	15
2.4	Measurement Mode.....	16
2.5	Recording measurements.....	16
2.6	Calibration	17
C	APPLICATION EXAMPLES	18
1	Strain gauge force sensor	18
2	Resistive distance sensor.....	19
3	Pressure sensor with current output	20
4	Measuring the distance vs. force characteristic	21

A HARDWARE

1 Safety instructions

Before installing the signal conditioner, read and follow these instructions.

The EMS750 signal conditioner is designed to process signals from strain gauge force sensors or other signals defined in this document. Do not use the signal conditioner for other purposes.

Do not exceed the supply voltage level of +30 VDC and input signals above 10 V (voltage inputs), or above 20 mA (current inputs).

Observe the ambient conditions: max temperature +50 °C, relative humidity (non-condensing) up to 95%.

It is forbidden to change or modify anything on the signal conditioner without the manufacturer's consent. In case of problems with installation, adjustment, etc., contact the manufacturer.

2 Signal conditioner installation

The signal conditioner is mounted on a 35 mm DIN rail. Installation near contactors and other high-current devices is not recommended, especially due to the interference that such devices cause. The working position of the signal conditioner is arbitrary.

3 Configuring the EMS750 signal conditioner

The configuration is understood as setting the signal conditioner inputs for measuring different types of signals. The **hardware configuration** consists of setting the jumpers on the printed circuit board and is described in this section. The **software configuration** can be performed after connecting the signal conditioner to the computer using the utility software (part B).

4 Opening the signal conditioner

On the signal conditioner, separate the upper part using a small screwdriver - see Fig. A-1. The separated part is in Fig. A-3. In case the upper part is also pulled out with the motherboard (Fig. A-2), both printed circuit boards must be separated. They are connected by a connector, in Fig. A-4 it is marked with a red arrow. The motherboard must then be inserted back into the box.

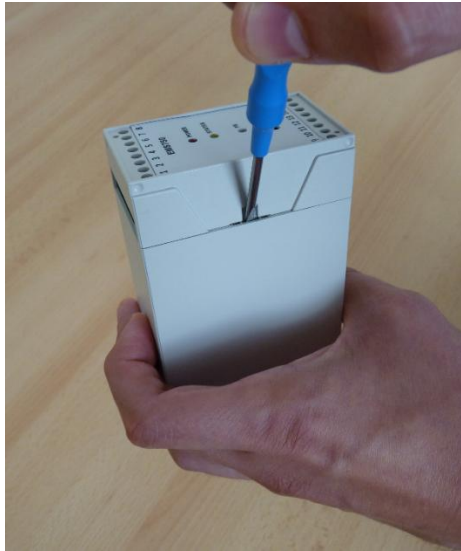

Fig A-1 Opening the signal conditioner

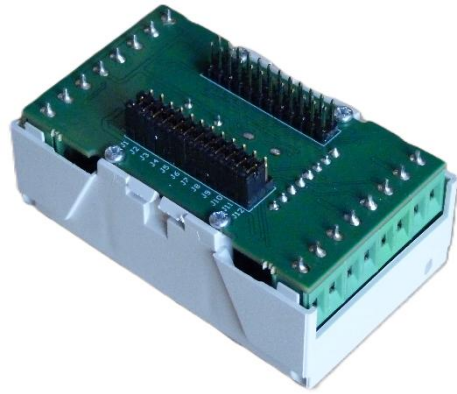

Fig A-3 Separate fornt part



Fig A-2 Front part with matherboard

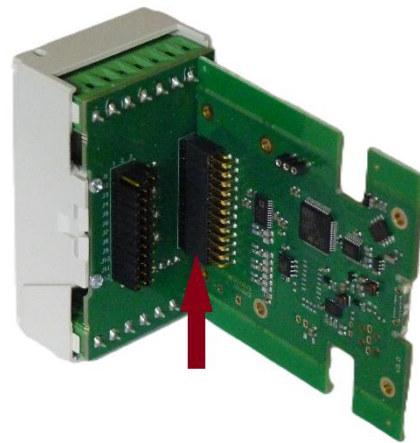

Fig A-4 Connecting connector

5 User Hardware Configuration

This section describes the configuration of the signal conditioner that can be performed by the user. Individual inputs (terminals) of the signal conditioner are configured, which are connected to groups of 4 terminals. Each group represents one channel, the signal conditioner has 4 channels marked CH1, CH2, CH3 and CH4. The distribution of channels and terminals is shown in Fig. A-5.

The signal conditioner inputs are configured using jumpers on the double-row connector from the bottom of the separate upper part of the signal conditioner, Fig. A-6. The signal conditioner has 12 configuration jumpers and each jumper must be installed. It is placed in position 1 – 2 or 2 – 3, according to the required input.

A description of the signal conditioner terminals and their configuration options is shown in Table 1.

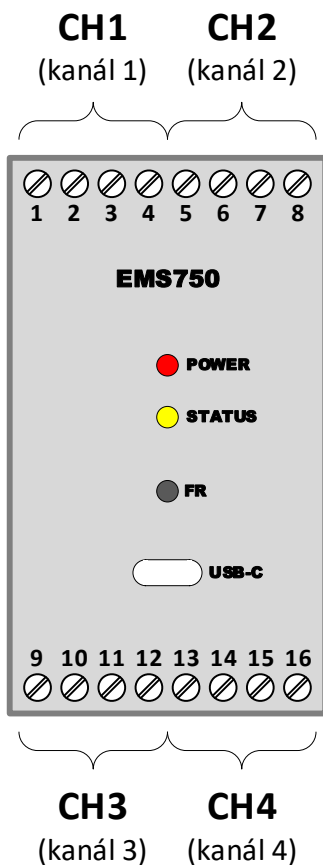

Fig A-5 Channels and terminals layout

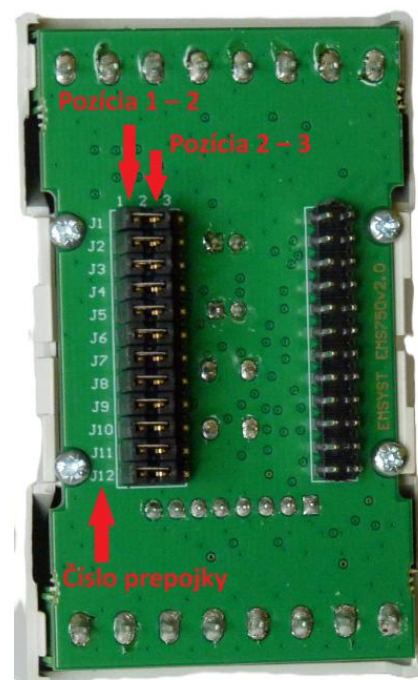

Fig A-6 Configuration connector

Tab 1. Terminal description and user configuration options

Input	Terminal number	Main function of the terminal	Alternative function
CH1	1	1 Exc + Sensor supply voltage +2.5 V	
	2	1 Exc – Sensor supply voltage 0 V	
	3	1 Sig + Sensor signal input + <i>J1: 1–2 = ON</i>	Input 0 – 10V * Positive signal input 0 – 10 V. Negative input connect to terminal 4. <i>J1: 2–3 = ON, J2: 1–2 = ON</i>
	4	1 Sig – Sensor signal input – <i>J2: 1–2 = ON</i>	Input 4 – 20 mA * Positive signal input 4 – 20 mA. Negative input connect to terminal 3 <i>J1: 1–2 = ON, J2: 2–3 = ON</i>
CH2	5	2 Exc + Sensor supply voltage +2.5 V	
	6	2 Exc – Sensor supply voltage 0 V	
	7	2 Sig + Sensor signal input + <i>J3: 1–2 = ON</i>	
	8	2 Sig – Sensor signal input – <i>J4: 1–2 = ON</i>	
CH3	9	3 Exc + Sensor supply voltage +2.5 V <i>J5: 1–2 = ON</i>	
	10	3 Exc – Sensor supply voltage 0 V <i>J6: 1–2 = ON</i>	
	11	3 Sig + Sensor signal input + <i>J7: 1–2 = ON</i>	
	12	3 Sig – Sensor signal input – <i>J8: 1–2 = ON</i>	
CH4	13	4 Exc + Sensor supply voltage +2.5 V <i>J9: 1–2 = ON</i>	Power External supply voltage 6 – 30 V <i>J9: 2–3 = ON</i>
	14	4 Exc – Sensor supply voltage 0 V <i>J10: 1–2 = ON</i>	GND External supply voltage 0 V <i>J10: 2–3 = ON</i>
	15	4 Sig + Sensor signal input + <i>J11: 1–2 = ON</i>	DI Digital input 0 / 30 V (max) <i>J11: 2–3 = ON</i>
	16	4 Sig – Sensor signal input – <i>J12: 1–2 = ON</i>	DO Digital output, open collector <i>J12: 2–3 = ON</i>

* It is possible to use only voltage or only current input, not both at the same time.

5.1 Configuration of inputs CH1, CH2, CH3 CH4 for connecting force sensors

The configuration of inputs for connecting strain gauge force sensors is the basic (default) configuration. In this case, all 12 jumpers are set to position 1 – 2, as shown in Fig. A-6. In this configuration, power supply is possible only via the USB bus. The sensor connection is shown in Fig. A-7, the wire colours apply only to Emsyst sensors.

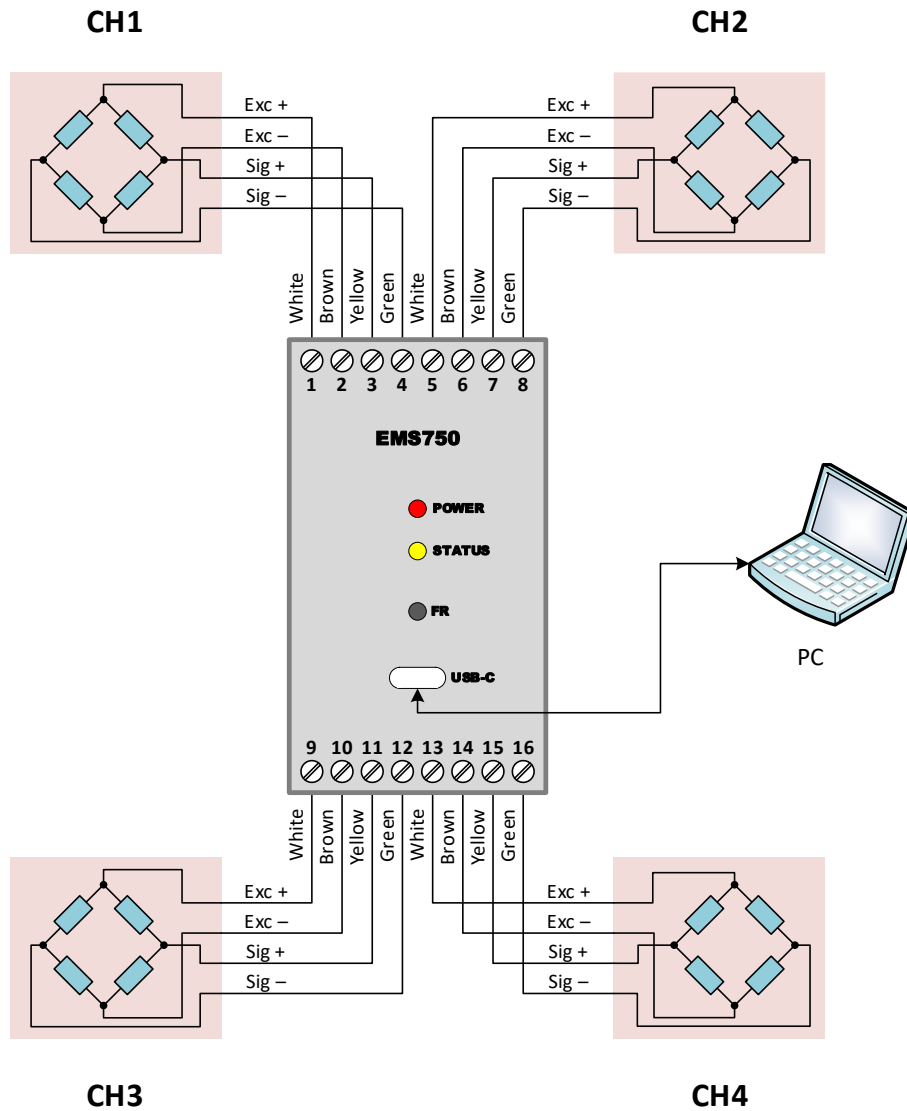

Fig A-7 Connection of 4 strain gauge force sensors

5.2 Configuration of input CH1 for voltage measurement 0 ... 10 V

The voltage signal is connected to input CH1, terminals 3 (+) and 4 (-), Fig. A-8. The other channels can be used arbitrarily and the power supply of the sensor of channel CH1 can also be used. An example is in Fig. A-9 where the potentiometer is powered by a voltage of +2.5 V.

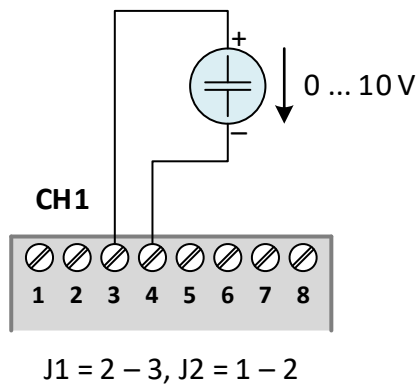

Fig A-8 Voltage input 0...10 V

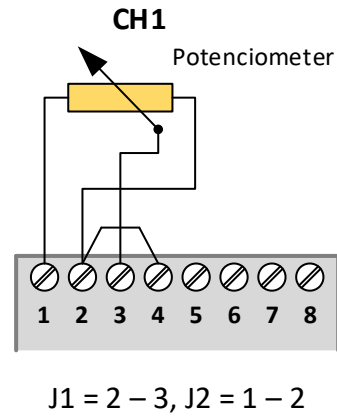

Fig A-9 Voltage input using sensor power supply

5.3 Configuring the CH1 input for 4 ... 20 mA current measurement

A device with a current output is also connected to the CH1 channel, but with the opposite polarity, i.e. the positive current direction to terminal No. 4 and the negative to terminal No. 3, see Fig. A-10. The current signal is used as standard in the range of 4 ... 20 mA, but measurement in the range of 0 ... 20 mA is also possible.

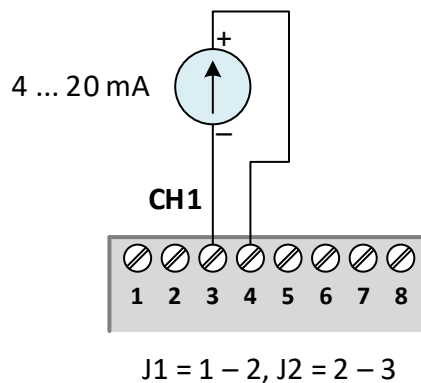

Fig A-10 Current input 4 ... 20 mA

5.4 CH4 channel configuration

CH4 channel can be configured as follows:

- - Terminals 13 (+) and 14 (GND) as input for external power supply (J9 = 2 – 3, J10 = 2 – 3) in the range of 6 to 30 VDC. Jumper setting: J9 = 2 – 3, J10 = 2 – 3.
- - Terminal 15 (to GND) as digital input. Activated by connecting to ground with a potential-free contact or using a transistor. Jumper setting: J11 = 2 – 3.
- - Terminal 16 (to GND) as digital output. It is connected as an open collector, the maximum switching voltage can be 30 V. Jumper setting “J12” = 2 – 3.

An example of the connection is shown in Fig. A-11. The DI button is used as a digital input, and the RE auxiliary relay is used as a digital output. The nominal switching voltage of the relay must be the same as the supply voltage of the signal conditioner. The contactless switching method of DI is shown in Fig. A-12. The input and output switching logic is set in the operating program.

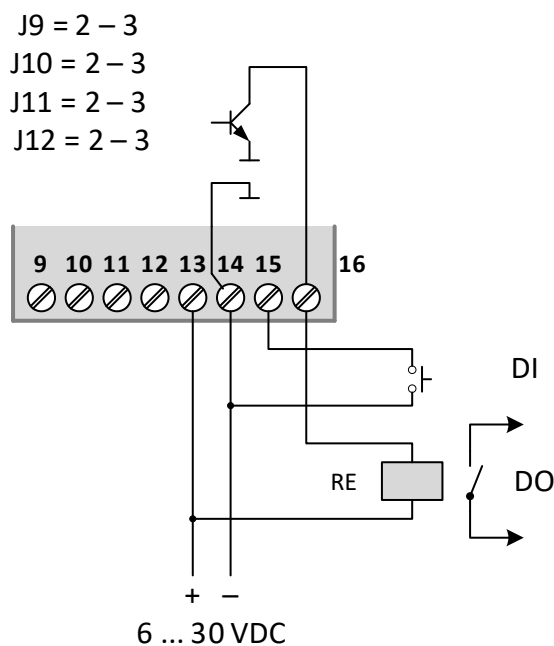

Fig A-11 Configuration of the channel CH4

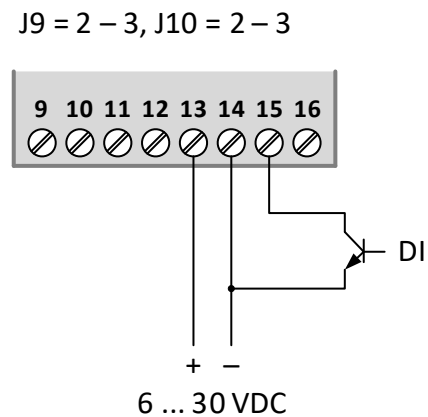

Fig A-12 Contactless DI switching

6 Advanced Configuration

The EMS750 transmitter can also be configured for other functions and signal sources, e.g. 7-channel measuring center, etc. However, such configuration must be performed by the manufacturer, therefore it is necessary to consult the configuration requirements with the transmitter manufacturer.

7 Technical data

Electronic parameters	
<u>Inputs</u> <ul style="list-style-type: none"> - 4x differential input for strain gauge sensor - 1x voltage input - 1x current input - 1x digital input 	<ul style="list-style-type: none"> - ± 7 mV/V - 0 ... 10 V - 0 ... 20 mA - 0V (Low) / 3...24 VDC (High)
<u>Digital output</u>	Open collector 30V / 1 A
<u>Sensor power supply</u>	2.5 V / 60 mA
<u>AD converter</u>	Sigma-Delta, int. resolution 24 bit
<u>Temperature coefficient</u> <ul style="list-style-type: none"> - Input voltage (offset) - Gain 	<ul style="list-style-type: none"> - 0.5 μV / $^{\circ}$C - 20 ppm / $^{\circ}$C
<u>Online data transmission</u> <ul style="list-style-type: none"> - Transmission speed 	- 1 ... 100 readings per second
<u>Data recording on Excel sheet</u> <ul style="list-style-type: none"> - Recording speed - Max recording capacity 	<ul style="list-style-type: none"> - 1 ... 100 readings per second - 16.000.000 readings
<u>Device power supply</u> <ul style="list-style-type: none"> - From USB interface - From external source - Max current consumption including sensors 	<ul style="list-style-type: none"> - 5 VDC - 6 ... 30 VDC (nom. 24 VDC) - 80 mA
Connecting to PC	
Connection type	USB 2.0 (virtual Com Port)
Connector type	USB-C
Transmission parameters	115200 Bd, 8 bit, no parity, 1 stop
Transmission protocol	ASCII, JSON
Ambient conditions and mechanical design	
Operating temperature	0 ... + 50 $^{\circ}$ C
IP protection	IP40
Dimensions (w x h x d)	45 x 75 x 110 mm
Weight	250 g
Mechanical mounting	DIN rail

B SOFTWARE

1 Control700 Program

The **Control700** program was created as an Excel **add-in** for setting up the EMS750 signal conditioner and collecting data. It only works in the Excel environment (from version 2019) and must be installed before first use as described below.

It is also possible to communicate with the signal conditioner using other programs, provided that the correct communication protocol is used. For more information, contact the manufacturer.

1.1 Control700 Installation

When installing for the first time, the add-in is first saved to a folder where it will remain for the entire period of its use. The add-in is then registered in Excel. This ensures that it is automatically launched each time Excel is opened.

Installation procedure:

- Create a folder to save the add-in. **Example: This computer > Documents > EMS750 > Add-in**
- Download or copy the **Control700.xlam** add-in and save it to the created folder.
- Open Excel and a **blank workbook** or any other file in it.
- Load the add-in in the standard way. Example: **File - Open - Browse - This computer > Documents > EMS750 > Add-in > Control700.xlam**
- Note. In some versions of Excel, the message **File is blocked** may appear when opening the add-in. In this case, the file must be unblocked as follows. Right-click on the Control700 file and open the Properties menu. There is an Unblock checkbox in the menu. Check the checkbox and confirm by pressing OK.
- After loading the add-on, a new tab called **Control700** will be created on the ribbon.
- Click on **File – Options – Add-Ins** and then on the **Go...** button. The **Add-ins** window will appear.
- In the window click on **Browse** and find the **Control700** Add-In. Select it and confirm by pressing OK.
- Control700 will be added to the **Available Add-Ins** list, including the checked checkbox. The Add-in is now installed and can be used.

1.2 Deactivating and activating the add-in

Deactivating the add-in removes the Control700 tab on the ribbon. However, the add-in itself remains in Excel, and it can be activated later.

Deactivation procedure:

- Open Excel and switch to the list of add-ins: **File – Options – Add-ins**. Then press the **Go...** button to open the **Add-ins window**.
- In the window, uncheck the **Control700** box and confirm by pressing OK.
- Close Excel (no saving of changes is required).
- The next time you open Excel, the **Control700** tab will no longer be on the ribbon.

When **activating** the add-in later, proceed in the same way, i.e. open the Add-ins window. Then check the check box next to Control700 to activate the add-in.

1.3 Uninstalling an Add-in

Uninstalling is done simply by deleting or renaming the add-in. However, when opening Excel, an error message appears stating **Sorry, we couldn't find...**, including a question as to whether you wish to remove it. Confirm the message by pressing OK, which will unregister it in Excel.

2 Control700, description of functions

The description assumes that the Control700 add-on is installed and the Control700 tab is open. This basic setting is shown in Fig. B-1.

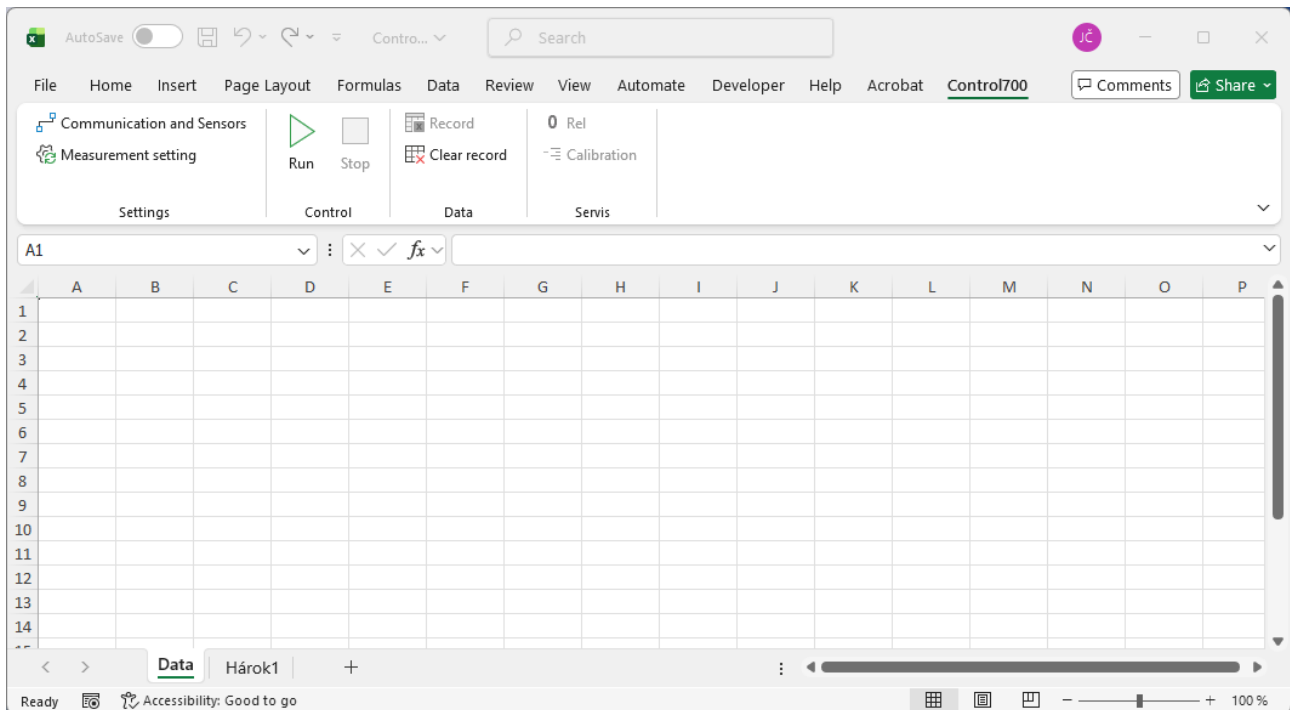

Fig B-1 Tab Control700

2.1 Connecting to communication ports

The menu for connecting transducers to communication ports is displayed after clicking on **Communication and Sensors**. A window will appear (Fig. B-2) that allows you to connect 4 transducers. The transducers are marked A, B, C, D.

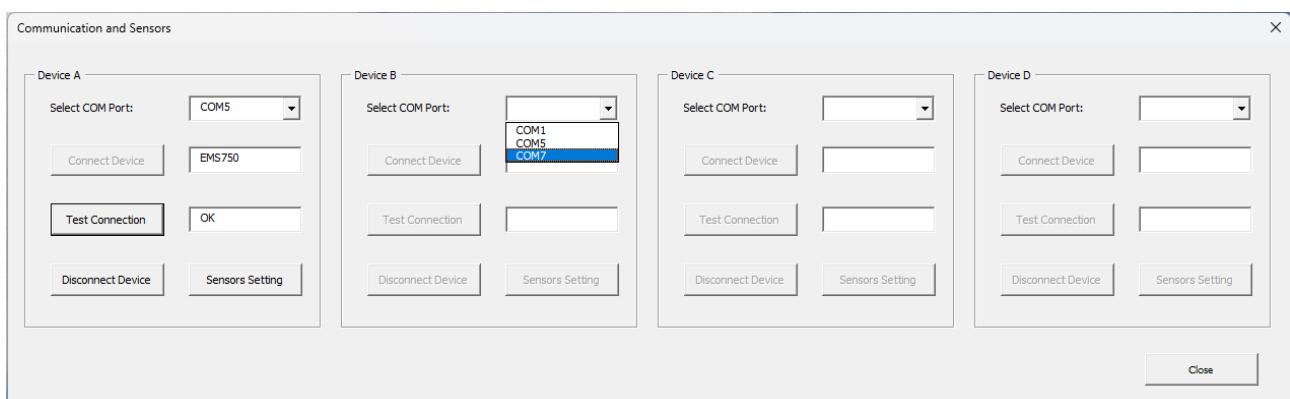

Fig B-2 Menu for connecting to communication ports

Communication port connection procedure

- Select the signal conditioner (A, B, C, D) and click on the **Select COM Port** drop-down menu. All free communication ports will be displayed.
- Select the communication port and click on the **Connect Device** button. After a short time, the type of connected signal conditioner will be displayed in the secondary window, in Fig. B-2 it is EMS750. Note. The program is universal, when using other devices (e.g. EMS720) a different type will be displayed.
- The **Test Connection** button allows you to test the connection. It is suitable for identifying the signal conditioner if more than one is connected.
- The **Disconnect Device** button can be used to disconnect the connected signal conditioner, thereby freeing up the communication port. However, the menu must be closed with the **Close** button and reopened because the list of free ports is created only when the menu is opened.
- After setting the ports, you can proceed to setting the sensors using the **Sensor Setting** button (described below). If they have already been set in the previous operation, the menu is closed with the **Close** button. This saves the settings in the signal conditioners. If the menu is closed only with the cross in the upper right, the window is closed but the set parameters are not saved.

2.2 Connecting the sensor

The sensor can only be set for one transducer at a time. Select the transducer according to the marking A, B, C or D and press the **Sensor Setting** button. (Fig. B-2). The window according to Fig. B-3 will open.

The screenshot shows the 'Sensor Setting - Device A' window with the following settings:

Input	Input type	Assigned Sensor Status	Title	SG Input range	SG Sensitivity	SG Zero error
Input 1	Voltage (0 ... 10 V)	Active	Angle	320	deg	2.5
Input 2	SG (Strain gauge / Force sensor)	Active	Force	100	N	1.5
Input 3	SG (Strain gauge / Force sensor)	Non Active	f3	300.00	N	1.2999
Input 4	SG (Strain gauge / Force sensor)	Non Active	f4	400.00	N	2.0000

Fig B-3 Sensor setting

Setup procedure

- A sensor with voltage or current output can only be connected to **Input 1**, strain gauge force sensors can be connected to any input. Depending on which sensor is connected, the Input type is set. Please note that it is also necessary to set the hardware jumper in the signal conditioner correctly - see section A.
- In the **Assigned Sensor Status** section, select **Active**.
- **Title**: a concise name for the sensor function, e.g. **Total force**, etc.

Setting other parameters depends on the type of sensor connected.

- **SG type sensor**
- **SG Input Range:** sensor range in units of force or weight
- **Units:** sensor range units, in this case force or weight
- **SG Sensitivity:** sensor sensitivity in mV/V
- **SG Zero error:** sensor zero error in mV/V

- **Voltage or Current type sensor**
- **Sensor Input Range:** sensor range in physical units, e.g. bar, m/s, etc. The unit can be any, but can have a maximum of 5 characters.
- **Output max:** maximum value of the sensor output in V or mA units
- **Output min:** minimum value of the sensor output in V or mA units
- Only a strain gauge force sensor can be connected to inputs 2, 3 and 4, it is set in the same way as the SG type sensor in the previous section.
- Input 4 can be used for external power supply of the signal conditioner. In this case, **Non Active** is set in **Assigned Sensor Status**.

More detailed information on setting sensor parameters is given in the examples in section C.

2.3 Setting measurement parameters

After connecting at least one signal conditioner, the **Measurement setting** item on the **Control700** tab becomes available. After clicking on the item, the window according to Fig. B-4 opens. The menu allows you to set some measurement parameters.

Fig B-4 Measurement parameter setting

Select channel for measurement. From the inputs to which sensors were connected, it allows you to select those that will be actually measured. After saving this menu, the headers of the channels that will be measured will be displayed on the sheet.

Sampling rate. The sampling rate (number of samples per second) is set independently of the number of measured channels.

Averaging filter. Averaging of input data, the number of values for the average can be selected in the range 1 ... 50.

Scrolling data. If this option is set, in Record mode the measured data will be scrolled depending on the number of measured data set.

Manual recording. Manual recording trigger suitable for non-automated measurements.

2.4 Measurement Mode

Press the **Run** button to start the measurement. In measurement mode, all active channels are sampled every second and the data is written to the columns for each channel (Fig. B-5).

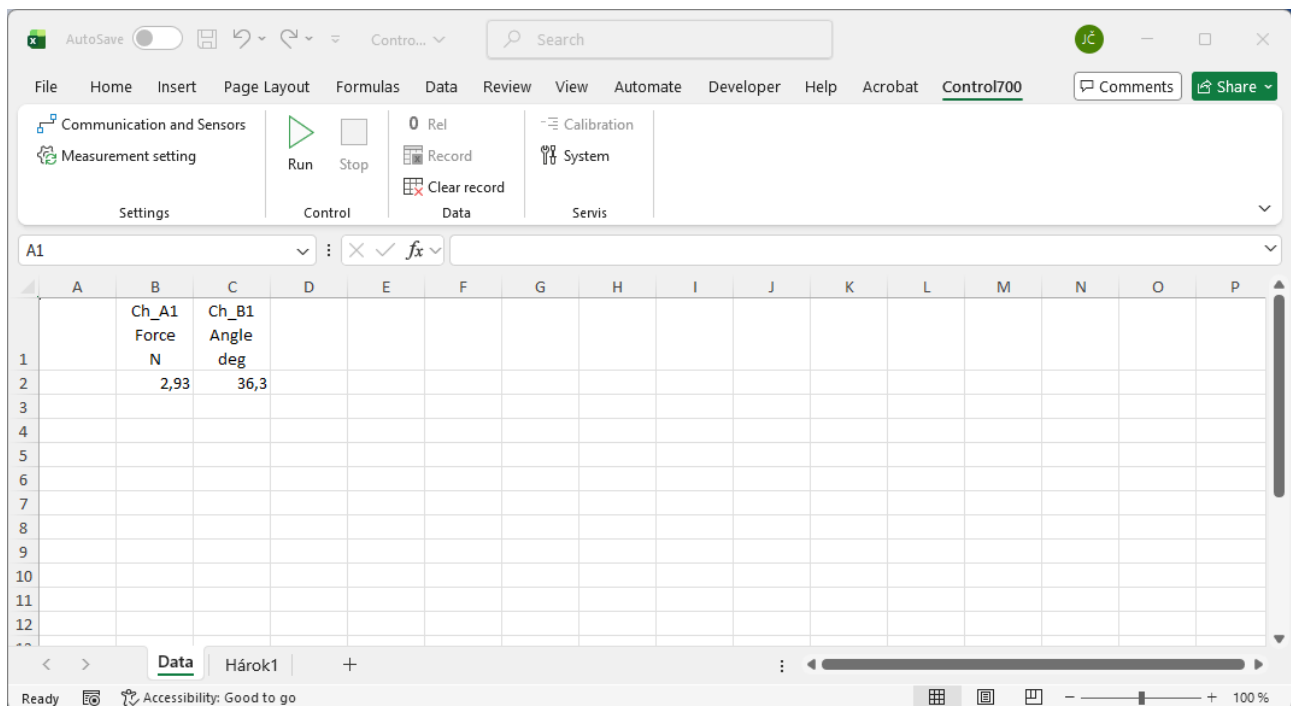

Fig B-5 Mode Run

The following buttons are active in measurement mode.

Stop measurement.

Rel Press this button to reset the measured channels. Press it again to cancel resetting.

Record data on a sheet, described below.

Calibration of individual channels, described below.

2.5 Recording measurements

Pressing the **Record** button starts recording data on the Data sheet. The signal conditioner starts measuring at the speed set in the **Sampling rate** parameter and writing to the sheet. Data transfer and therefore writing are done every second. The maximum number of recorded data can be **1,000,000**.

If the **Scrolling data option** parameter is set, only the set number of scrolled data is written.

If **Manual recording** is set, one line of data is written each time the **Record** button is pressed.

In cell **A1**, a parameter can be entered that specifies what should be written in the first column. The parameter can have the following values:

Time The measurement time is written.

No The measurement sequence number is written.

If the cell is left **empty**, nothing is written in the first column.

2.6 Calibration

A significantly more accurate measurement can be achieved by calibration. When calibrating, we recommend that the averaging filter be turned on and the number of values for the filter should be at least 10. Calibration can only be performed in measurement mode and only if one measurement channel is active. If these conditions are met, calibration is started by pressing the **Calibration** button. The calibration menu is displayed, Fig. B-6.

Fig B-6 Calibration menu

Calibration procedure

- Unload the force sensor or set it to the initial position if it is not a force sensor.
- If the unloaded (initial) position is zero, write zero in the **Target setpoint Low** box. If it is not zero, write the actual value. After writing, press **Write Low**.
- Load the sensor with a value close to the nominal value and wait until the data stabilizes. The measured value is displayed on the sheet as in the standard **Run** mode.
- Enter the value with which you loaded the sensor in the **Target setpoint High** box, then press **Write High**.
- Calibration is complete, the displayed data will become Target setpoint High, the menu can be closed with the **Close** button.

C APPLICATION EXAMPLES

1 Strain gauge force sensor

A signal conditioner needs to be set up for measuring a strain gauge force sensor EMS20-2kN with a sensitivity of 1.495 mV/V and a zero error of 0.032 mV/V.

Connection

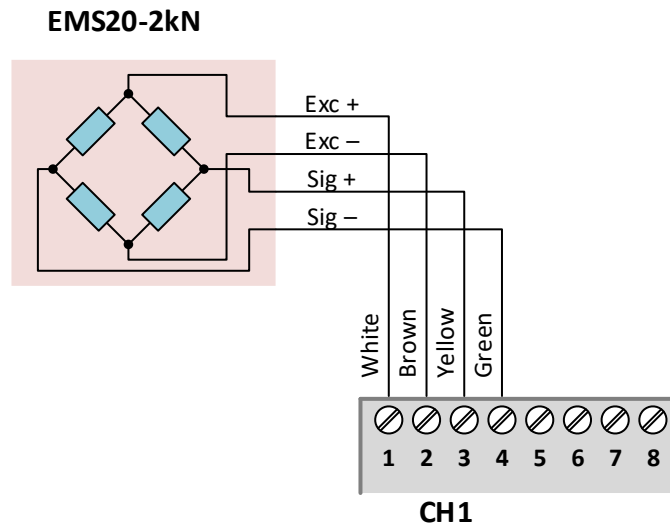

Setting

- Input type: SG
- SG Input range: 2
- Units: kN
- Sensitivity: 1,495
- Zero Error: 0,032

2 Resistive distance sensor

A potentiometric distance sensor with a range of 150 mm must be connected to the EMS750 signal conditioner so that it measures the distance via the runner.

Connection

Since this is a relatively high voltage, the potentiometer can only be connected to input 1, which is set to measure voltage in the range of 0 - 10 V. The potentiometer is connected to the signal conditioner terminals according to the figure, the voltage for powering force sensors with a nominal value of 2.5 V is used to power the potentiometer. In addition to the software settings, jumpers must also be set (the settings are in the figure).

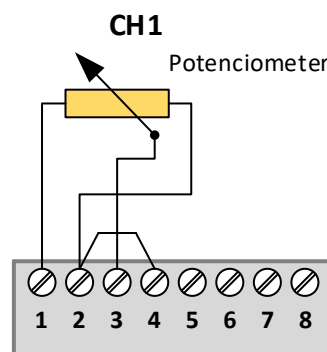

J1 = 2 - 3, J2 = 1 - 2

Setting

- | | |
|-----------------------|---------|
| - Input type: | Voltage |
| - Sensor Input Range: | 150 |
| - Units: | mm |
| - Output Max | 2,5 |
| - Output Min | 0,0 |

3 Pressure sensor with current output

A pressure sensor with a range of 250 bar and a current output of 4 – 20 mA is to be connected to the EMS750 transmitter. The supply voltage of the sensor is 24 V.

Connection

This is a current source that can only be connected to input no. 1. Since the pressure sensor must be powered by 24 VDC, it is advantageous to also power the transmitter itself with this voltage. Terminals 1 and 2 are unused in this case.

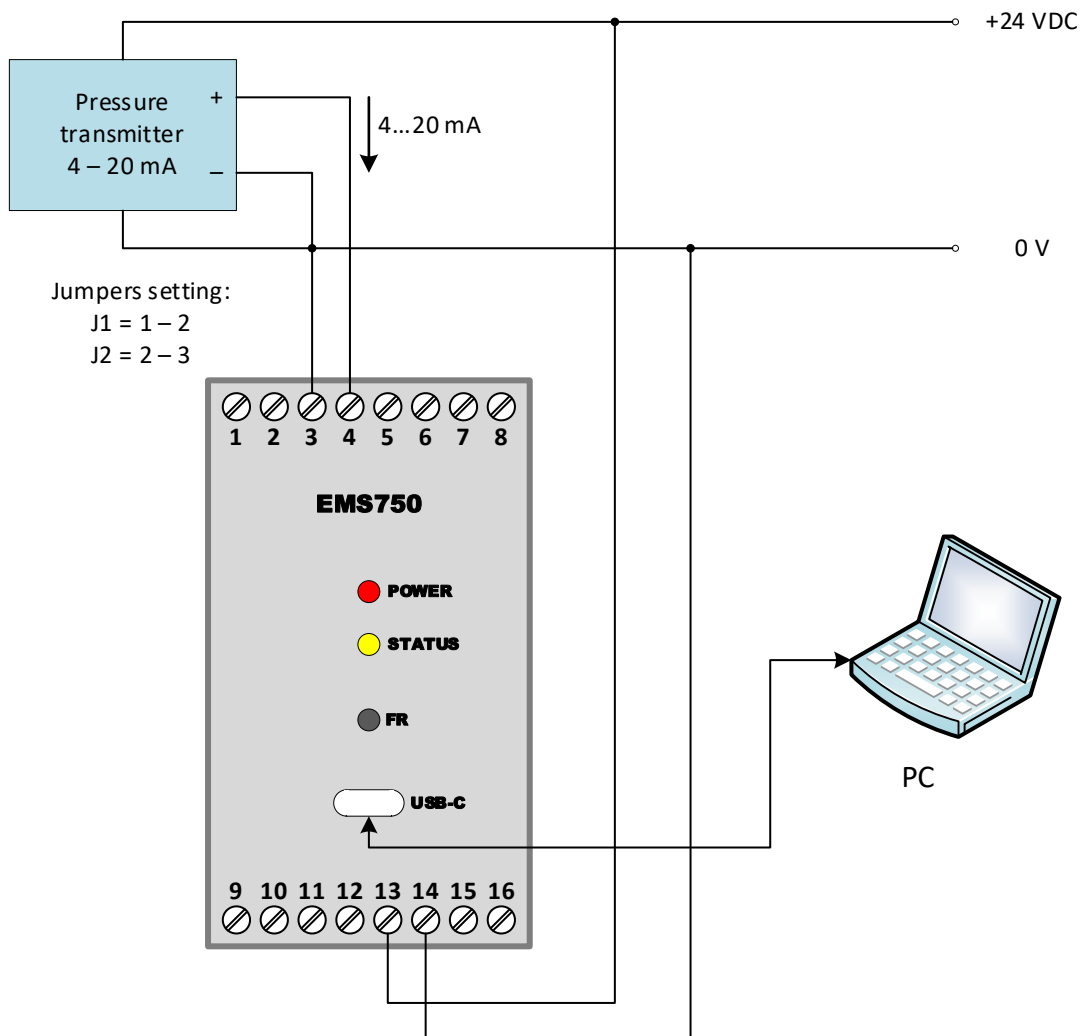

Setting

- | | |
|-----------------------|---------|
| - Input type: | Current |
| - Sensor Input Range: | 250 |
| - Units: | bar |
| - Output Max | 20 |
| - Output Min | 4 |

4 Measuring the distance vs. force characteristic

Measuring the characteristic distance vs. force, occurs quite often. Using the EMS750 signal conditioner, both quantities can be measured at the same time using the connection in the figure. Depending on the speed of change of path, it is necessary to set the appropriate sampling rate.

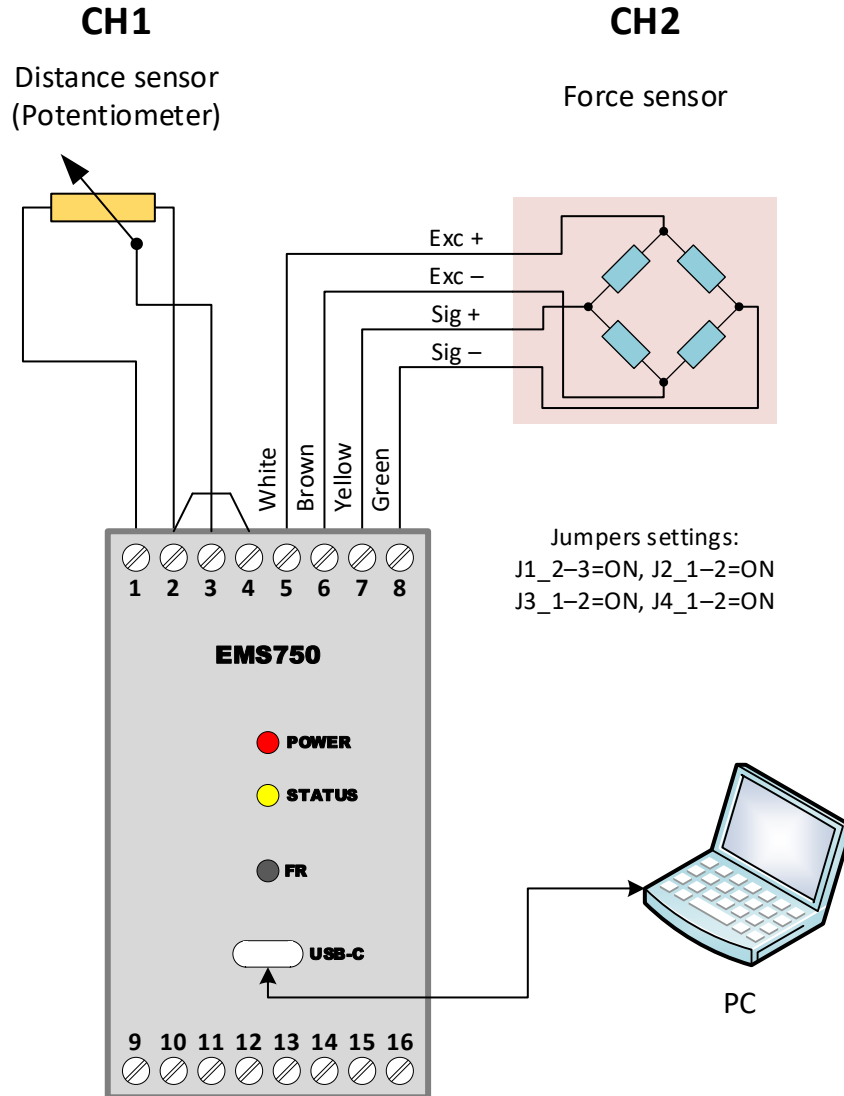

Legal information

The company EMSYST, spol. s r. o., registered office: Súvoz 111, 911 01 Trenčín, ID No.: 34 115 749, VAT No.: SK2020386115, registered in the Commercial Register maintained by the District Court Trenčín, section: Sro, file No.: 502/R (hereinafter referred to as the "Company"), hereby informs that any texts, descriptions, information, graphic and technical data contained in this document are subject to Company's copyright in accordance with the provisions of Act no. 185/2015 Coll. Author's of the Act, as amended. These materials are intended for customers of the Company and it is not possible to copy, modify or reproduce it without previous written consent of the Company.

The company further informs that any information that has been made available for customers, resulting from this document (primarily prices, technical know-how, or other special specification), relating to the Company's products and processes are the subject of a special trade secret of the Company and are subject to legal protection resulting from the provisions of § 17 et seq. Act No. 513/91 Coll. Commercial Code as amended.