



### Special features

- Mechanical design identical to **EMS20** type
- Strain gauge measuring system
- Tension / Compression
- Built-in signal conditioner with voltage and current output
- Possibility to use both outputs simultaneously
- Power supply: 5 ... 27 VDC

*The EMS21 sensor is used for force measuring in the direction of compression and tension. It has a built-in electronic signal conditioner which provides all standard output ranges, both voltage and current. It is also possible to use both outputs simultaneously. The sensor is particularly suitable for measuring forces on machines.*

### Overview of models

Model	Output (Vout, Iout)	Power supply (Vcc)
EMS21 – U(0.5 ... 4.5)	0.5 ... 4.5 V	5 ... 27 VDC
EMS21 – U(2.5 ± 2)	2.5 ± 2 V	5 ... 27 VDC
EMS21 – U(2 ... 10)	2 ... 10 V	11.5 ... 27 VDC
EMS21 – U(6 ± 10)	6 ± 4 V	11.5 ... 27 VDC
EMS21 – I(4 ... 20)	4 ... 20 mA	22 ... 27 VDC
EMS21 – I(12 ± 8)	12 ± 8 mA	22 ... 27 VDC

The version of the output as well as the range of the sensor and the direction of the load must be specified in the order. After the setting in the factory, it is no longer possible to change these parameters.

It is possible to use both voltage and current output simultaneously during operation. However, it is practical used only for the output 2 ... 10 V / 4 ... 20 mA or 6 ± 10 V / 12 ± 8 mA and the supply voltage 24 V. With other voltage outputs and smaller supply voltage, the current output is limited.

The adjustment of the sensor (within the permitted tolerances) is only possible for one output (either for voltage or for current). The output specified in the order is set.

## Specifications

Parameter	Value	Unit
Rated capacity ( $F_n$ )	0.1, 0.2, 0.5, 1, 2, 5	kN
Overload		
- <i>Safe</i>	130	% $F_n$
- <i>Ultimate</i>	150	% $F_n$
- <i>Permanent static load (recommended value)</i>	75	% $F_n$
- <i>Dynamic load (recommended value)</i>	50	% $F_n$
Output tolerance		
- <i>Voltage output</i>	$\pm 80$	mV
- <i>Current output</i>	$\pm 0.16$	mA
Output load impedance		
- <i>Voltage output (min)</i>	2	k $\Omega$
- <i>Current output (max)</i>	500	$\Omega$
Cut-off frequency of built-in amplifier ( $-3$ dB)	200	Hz
Max error		
- <i>Non-linearity</i>	0.25	% F.S.
- <i>Hysteresis</i>	0.25	% F.S.
Temperature range		
- <i>Nominal</i>	0 ... + 50	$^{\circ}\text{C}$
- <i>Operating</i>	- 10 ... + 50	$^{\circ}\text{C}$
Temperature drift		
- $\Delta V_{out} / \Delta T$ (max)	$\pm 1.5$	mV / $^{\circ}\text{C}$
- $\Delta I_{out} / \Delta T$ (max)	$\pm 3$	$\mu\text{A} / ^{\circ}\text{C}$
Power supply ( $V_{cc}$ )		
- <i>Range</i>	5 ... 27	VDC
- <i>Current consumption (max)</i>	40	mA
Power supply drift ( $V_{cc} = 5$ V or 24 V)		
- $\Delta V_{out} / \Delta V_{cc}$ (max)	$\pm 20$	mV / V
- $\Delta I_{out} / \Delta V_{cc}$ (max)	$\pm 40$	$\mu\text{A} / \text{V}$
Connection cable		
- <i>Type</i>	LifYDY 7x0.05	
- <i>Length</i>	2	m
- <i>Outer diameter</i>	4.5	mm
Protection	IP54	

## How to order

Common formula for ordering:

***EMS21-U/I(output range) – force range – load direction***

- Sensor type with type of output:
  - EMS21-U – voltage output
  - EMS21-I – current output
  
- Voltage output ranges:
  - 0.5 ... 4.5 V
  - $2.5 \pm 2$  V (zero shifted to 2.5 V)
  - 2 ... 10 V
  - $6 \pm 4$  V (zero shifted to 6 V)
  
- Current output ranges:
  - 4 ... 20 mA
  - $12 \pm 8$  mA (zero shifted to 12 mA)
  
- Measured force range (kN):
  - 100N, 200N, 500N, 1 kN, 2 kN, 5 kN
  
- Load direction:
  - Compression
  - Tension
  - Compression/Tension (both)

Examples:

200N sensor with voltage output 2 ... 10V, load direction compression, order:

***EMS21-U (2 ... 10V) – 200N – Compression***

1kN sensor with current output with shifted zero, load direction Compression and Tension, order:

***EMS21-I (12 ± 8 mA) – 1kN – Compression/Tension***

## Outline dimensions

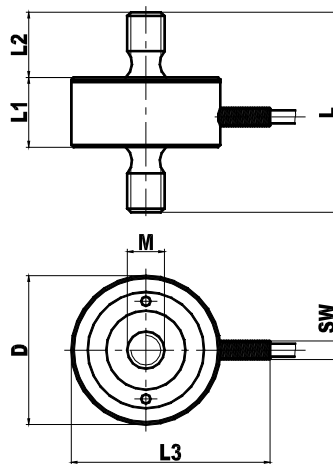

Rated capacity $F_n$ (kN)	D mm	M mm	L mm	L1 mm	L2 mm	L3 mm	SW mm	Mass kg	Deflection, @ $F_n$ ( $\mu\text{m}$ )	Body material
0.1, 0.2, 0.5	28	M6	34	14	10	38	$\Phi 4$	0.05	35	Aluminium
1, 2, 5	32	M8	43	15	14	42	$\Phi 4$	0.1	45	Stainless steel

## Recommended installation

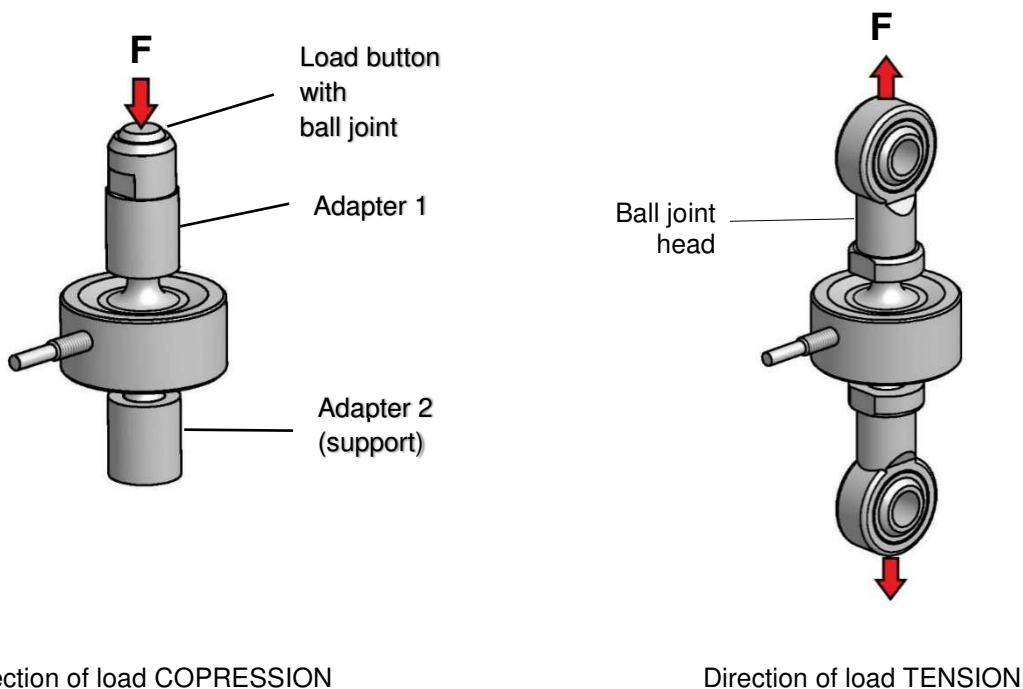

### Installation notes:

- The force must only act in the axis of the sensor.
- The sensor must be built in such a way that the force acts only through the threads. Adapter or the ball joint head must not touch the sensor body itself.

## Wiring diagram

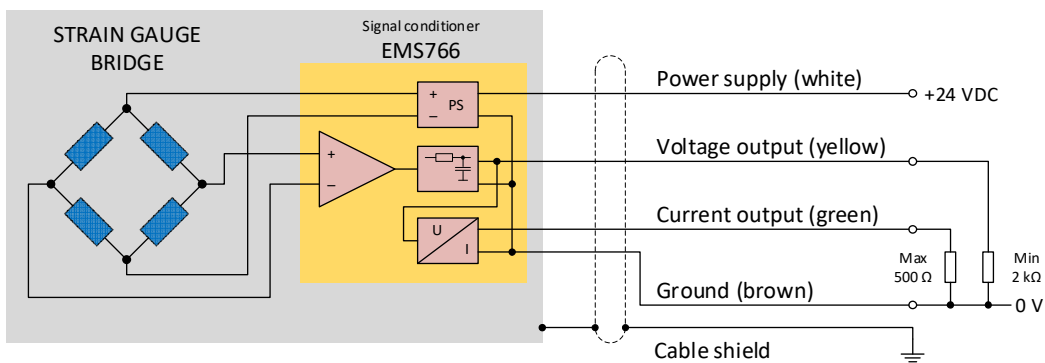

## Output characteristics

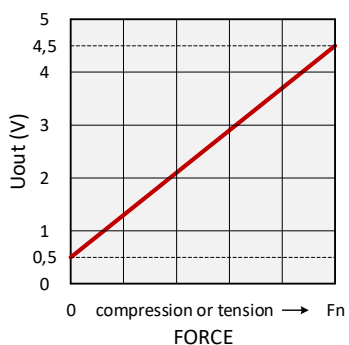

$U(0.5 \dots 4.5 \text{ V})$

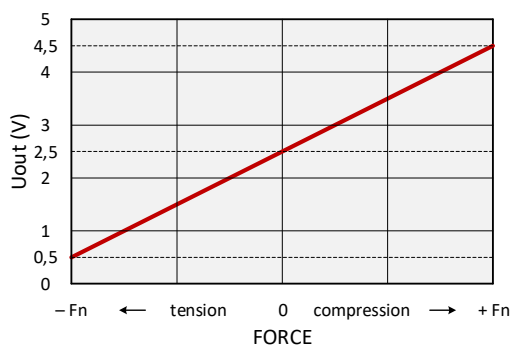

$U(2.5 \pm 2 \text{ V})$   
zero shifted to 2.5 V

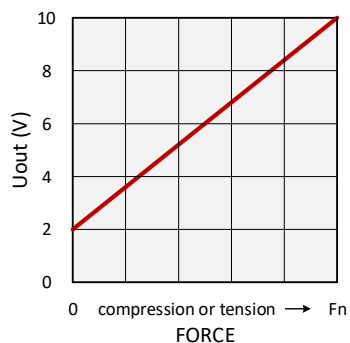

$U(2 \dots 10 \text{ V})$

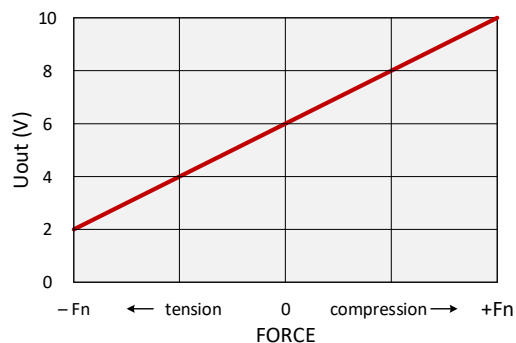

$U(6 \pm 4 \text{ V})$   
zero shifted to 6 V

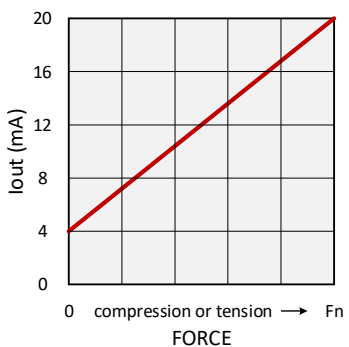

$I(4 \dots 20 \text{ mA})$

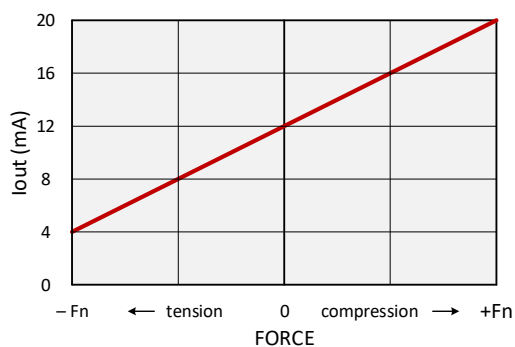

$I(12 \pm 8 \text{ mA})$   
zero shifted to 12 mA

## Legal information

The company EMSYST, spol. s r. o., registered office: Súvoz 111, 911 01 Trenčín, ID No.: 34 115 749, VAT No.: SK2020386115, registered in the Commercial Register maintained by the District Court Trenčín, section: Sro, file No.: 502/R (hereinafter referred to as the "Company"), hereby informs that any texts, descriptions, information, graphic and technical data contained in this document are subject to Company's copyright in accordance with the provisions of Act no. 185/2015 Coll. Author's of the Act, as amended. These materials are intended for customers of the Company and it is not possible to copy, modify or reproduce it without previous written consent of the Company.

The company further informs that any information that has been made available for customers, resulting from this document (primarily prices, technical know-how, or other special specification), relating to the Company's products and processes are the subject of a special trade secret of the Company and are subject to legal protection resulting from the provisions of § 17 et seq. Act No. 513/91 Coll. Commercial Code as amended.